

---

## - Slimani Ring -

- YOUR LIVINGROOM EVERYWHERE -

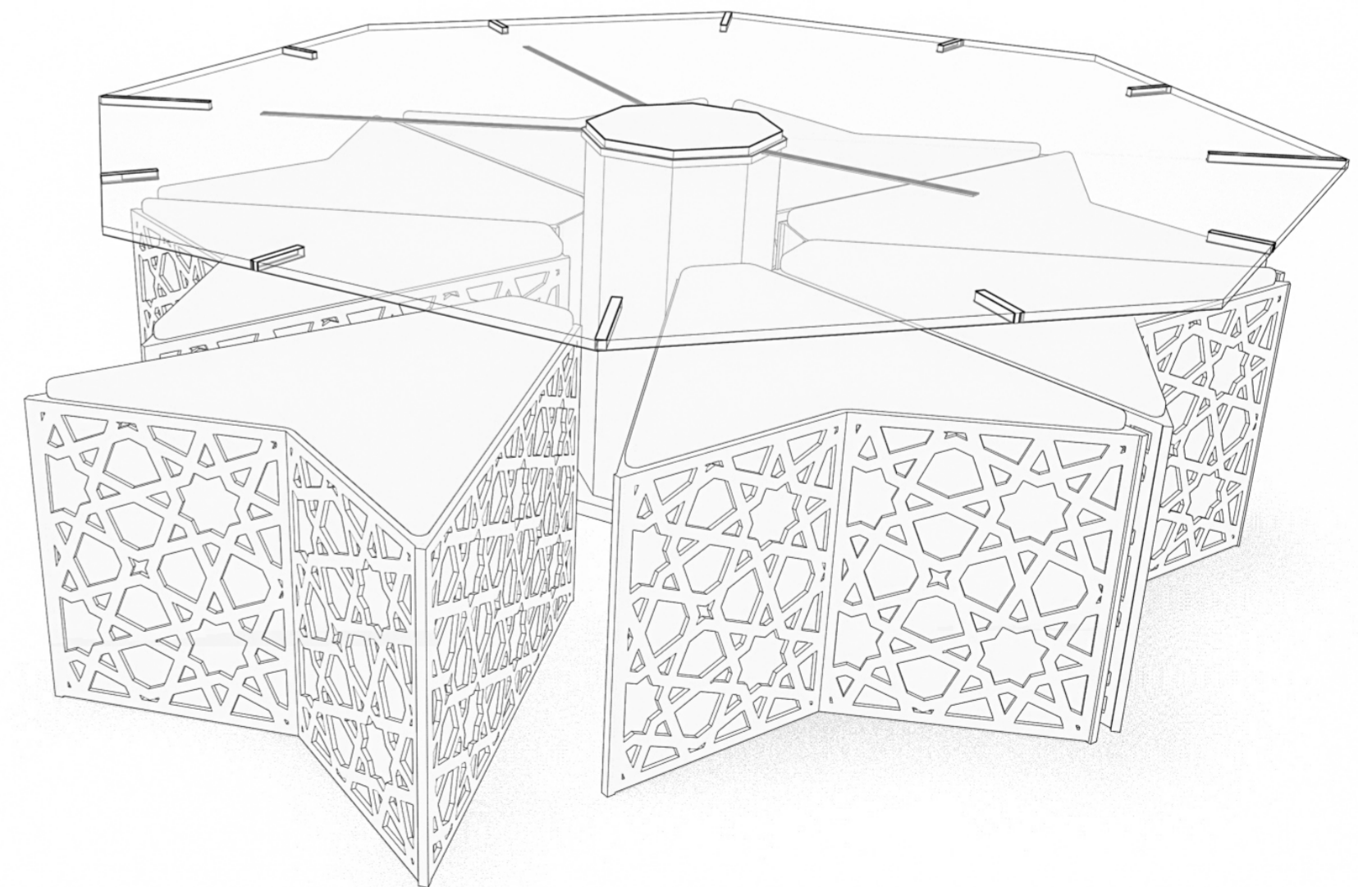

- Concept -

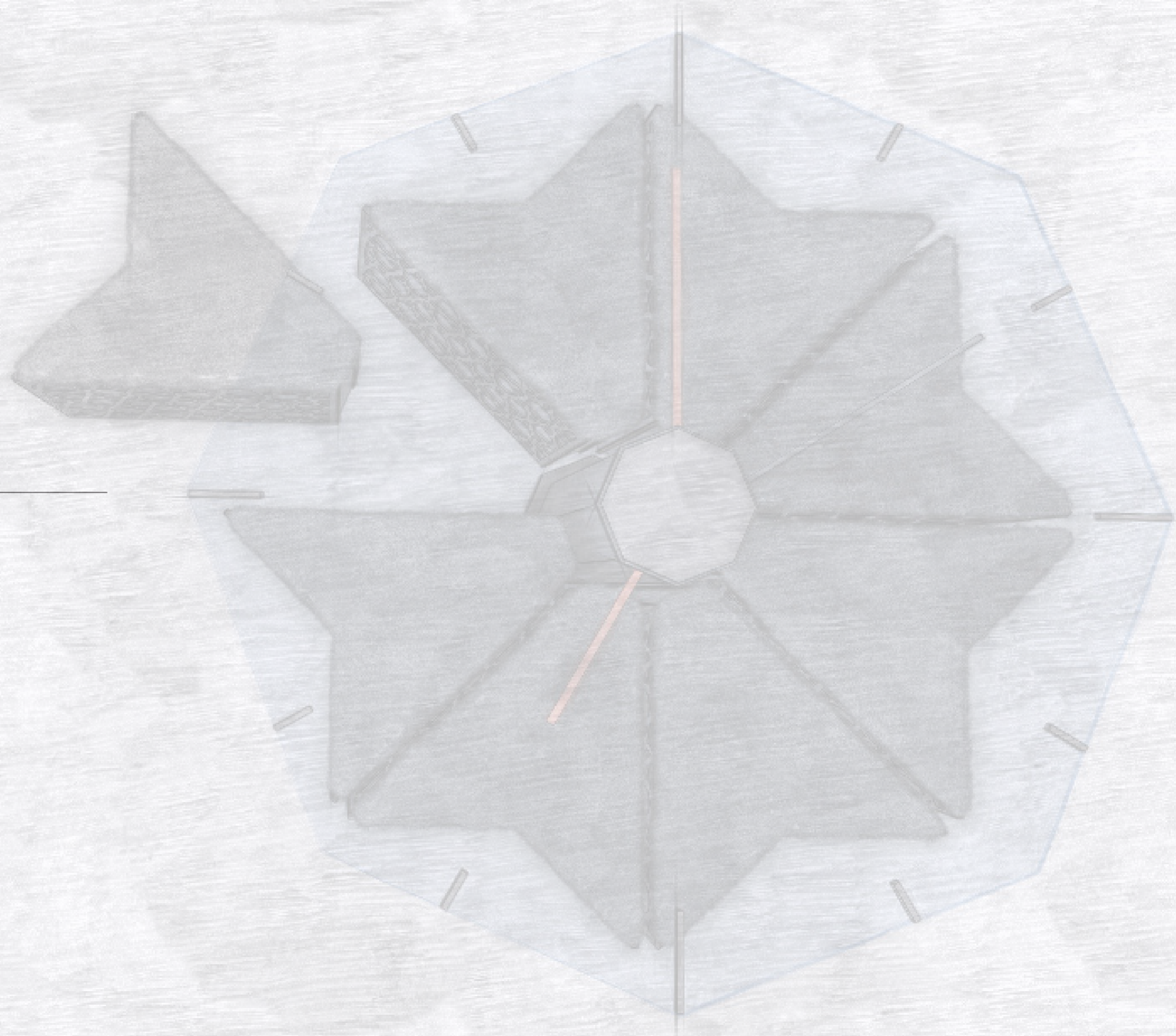

ORIGIN

The idea of our product is based on one of the main figures and basis of Islamic art, the rub al-hizb, in Arabic: rub "square" - hizb "group" or "part".

It is an Islamic symbol represented with the eight-pointed cross obtained by the superposition of two squares rotated 45 degrees between them. This symbol was used in Tartessus, an ancient civilization of southern Spain, representing the eight centuries of domination of the Islamic dynasties over the region.

The same symbol returns in the Jewish religion with the name of Seal of Melchizedek, and in the Hindu culture as the star of Lakshmi, where the eight points represent eight secondary manifestations of Lakshmi, goddess of wealth.

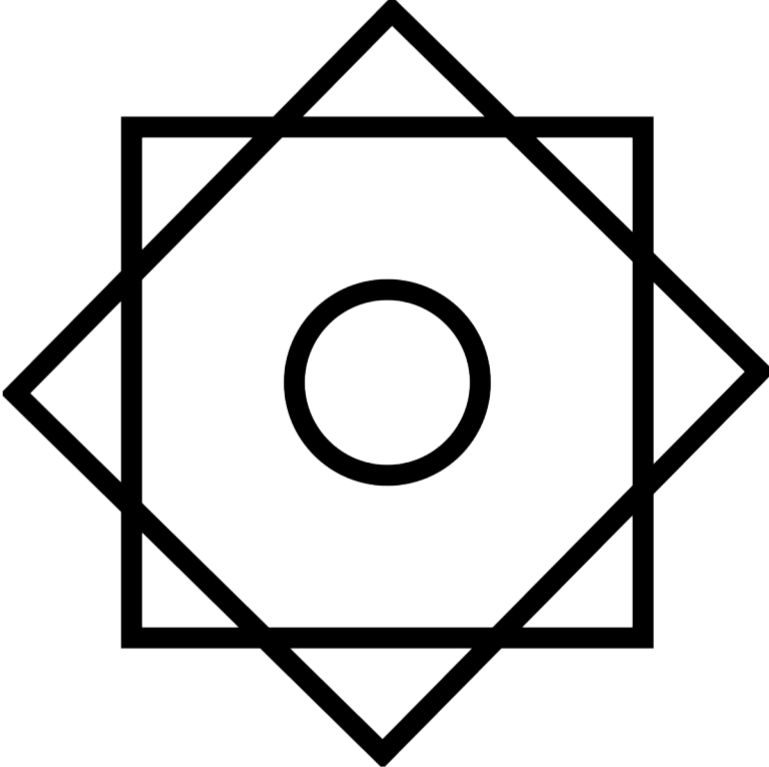

Rub al-Hizb

## IDEA

The project was designed to split and reconcile modern design with the art and style of Moroccan furnitures.

We thought of a simple, modern product with traditional shades, versatile, easily reproducible with eco-sustainable materials.

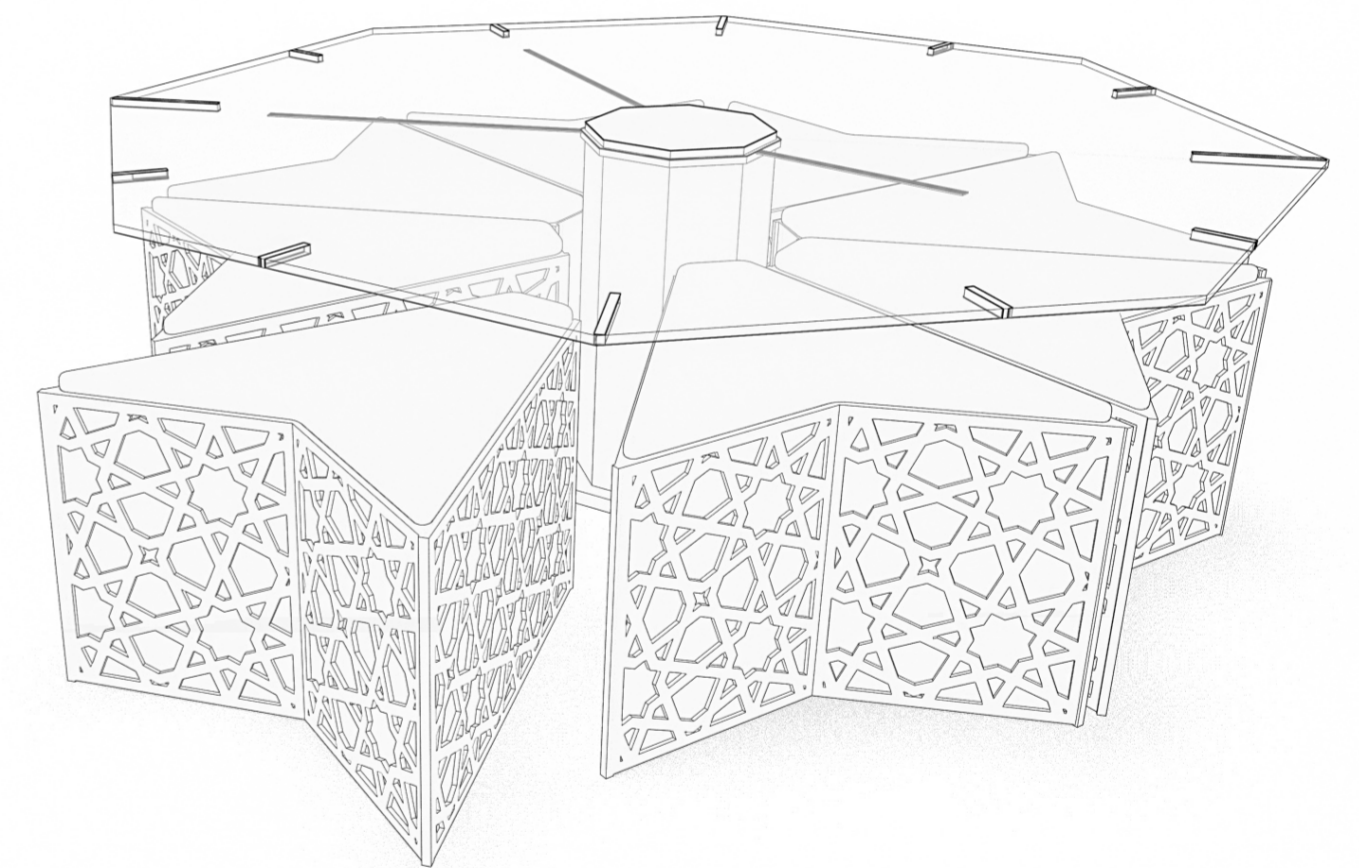

## IDEA

### THIS PRODUCT IS:

- **SELF-SUFFICIENT**, as it does not require additional objects or furnishings to complete its functionality;
- **VERSATILE**, as it can be used as a reading table, a dining table and as a meeting table;
- **EASILY INTEGRABLE**, It matches both of modern and classic environments;
- **ECO-FRIENDLY**, because of the use of eco-sustainable materials.

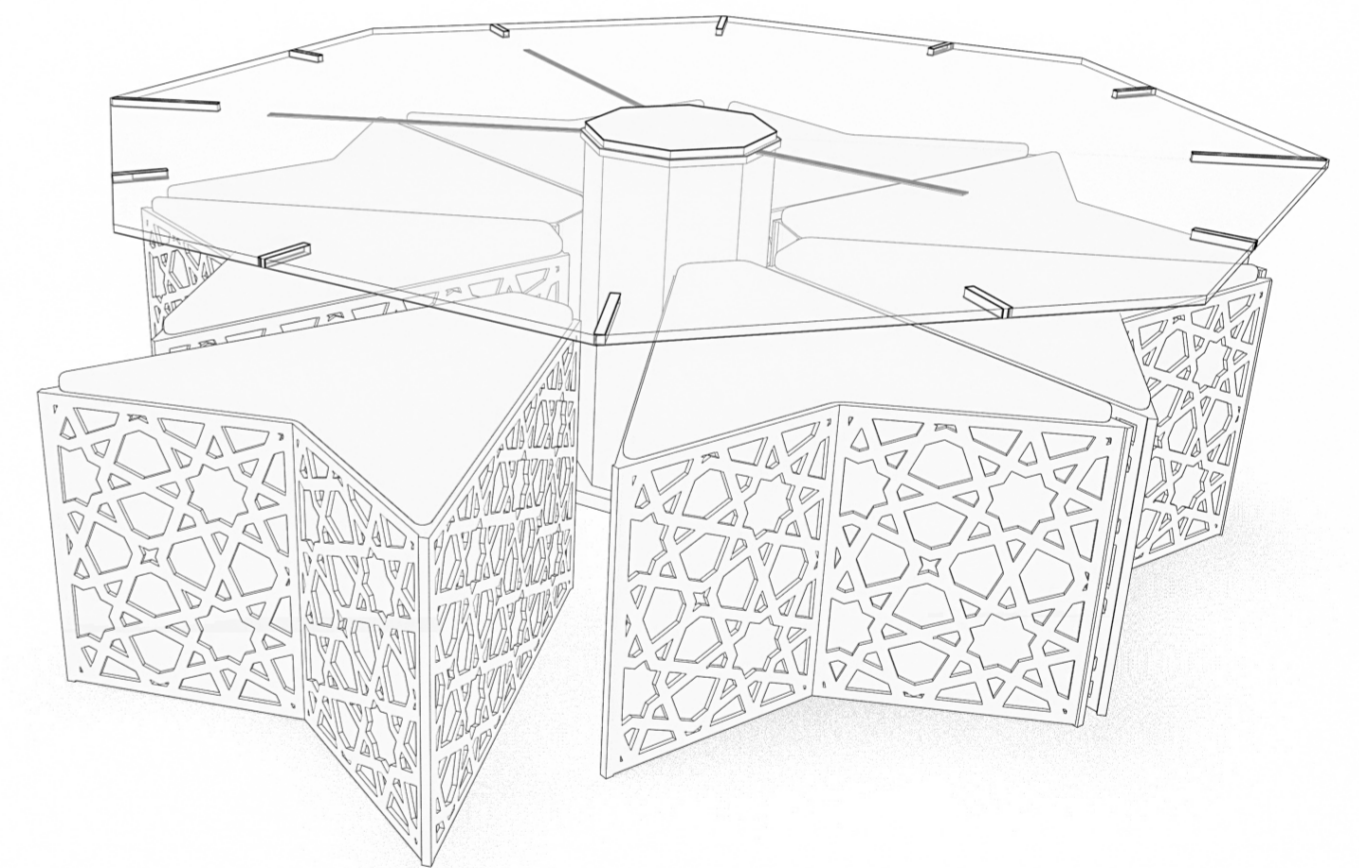

PRODUCT

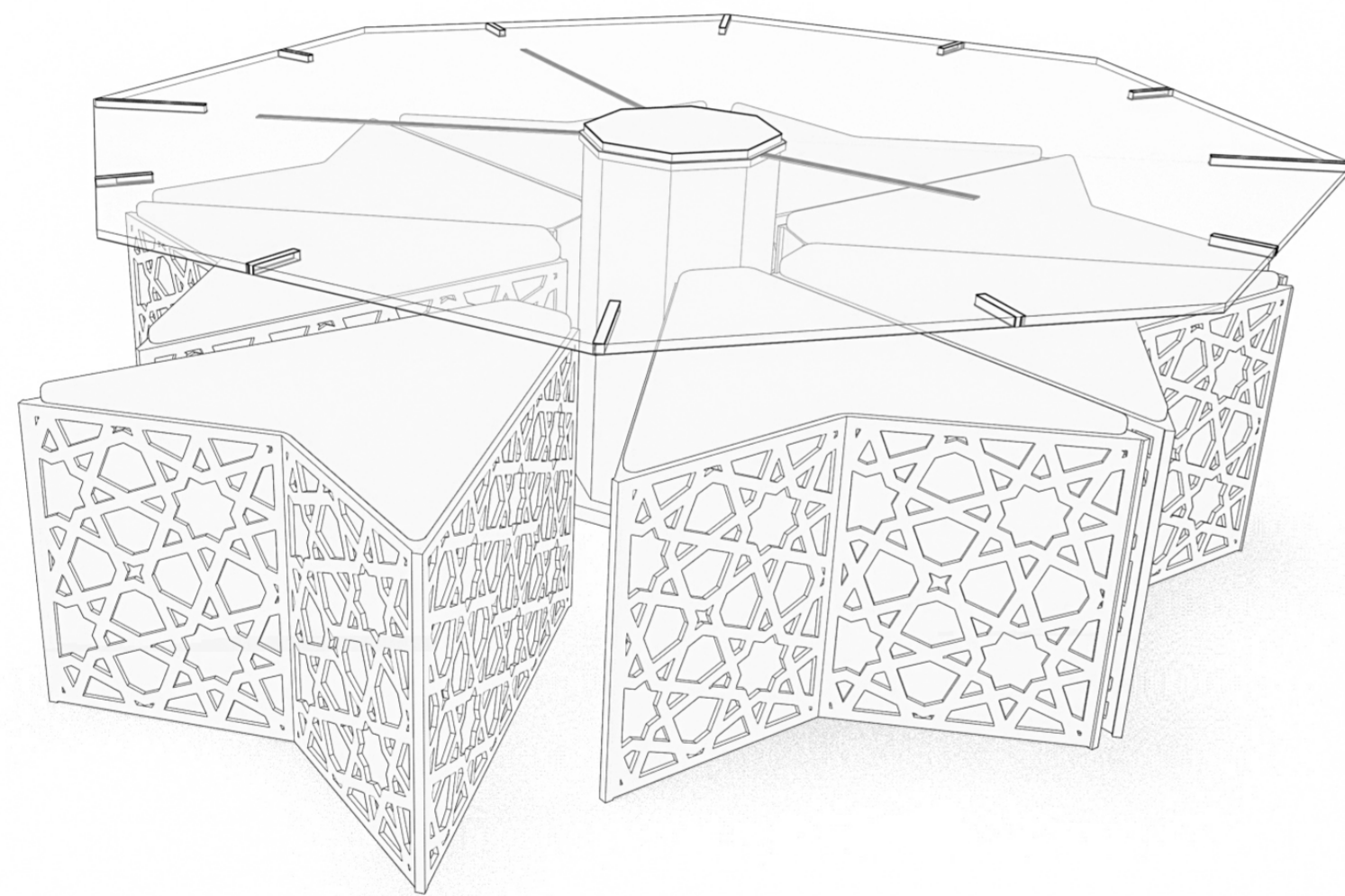

## COMPONENTS

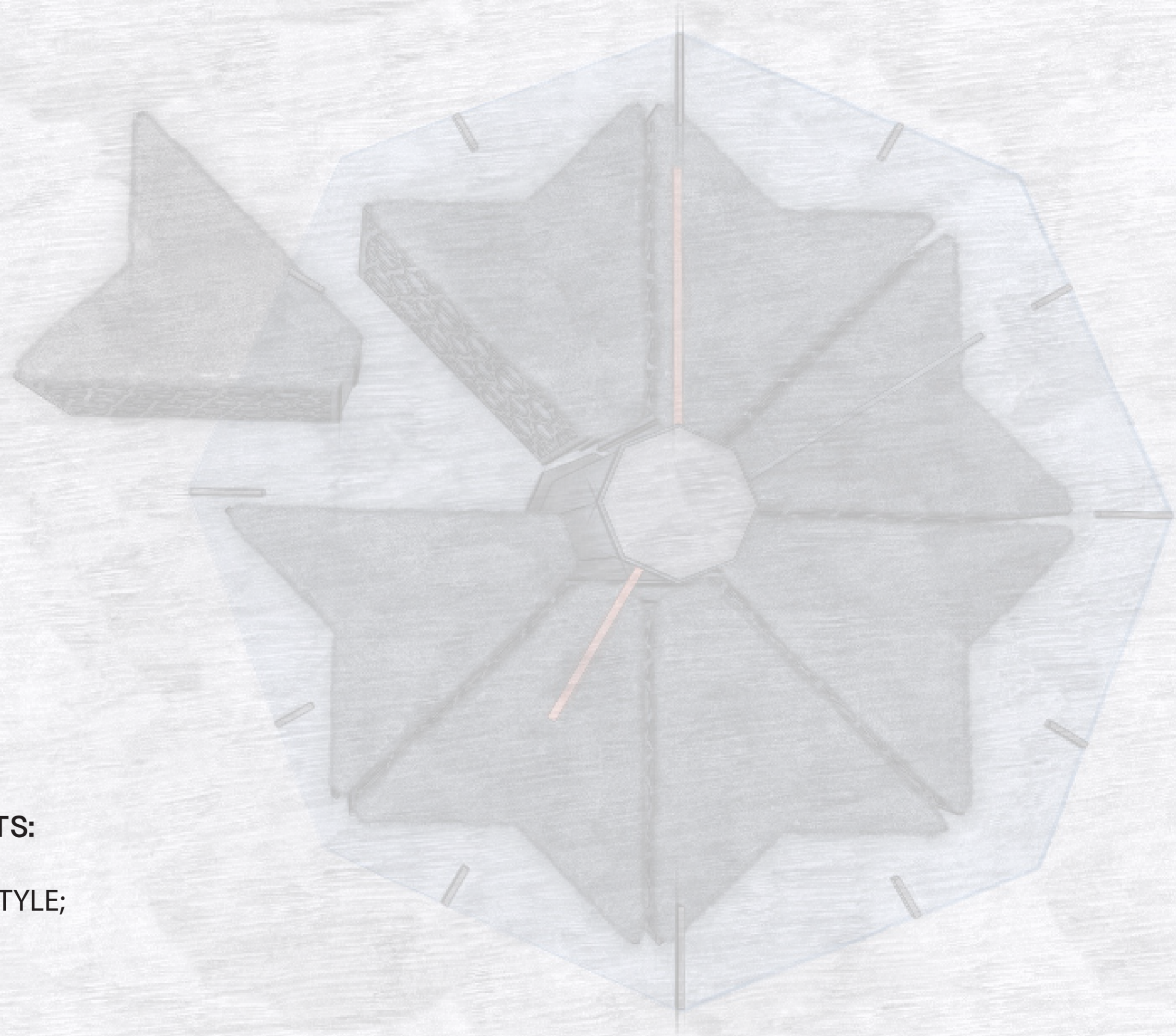

**THE PRODUCT IS MAINLY  
COMPOSED BY TWO ELEMENTS:**

1. MODULAR SEATINGS (8) POUF STYLE;
2. CLOCK TABLE.

## 1. MODULAR SEATS

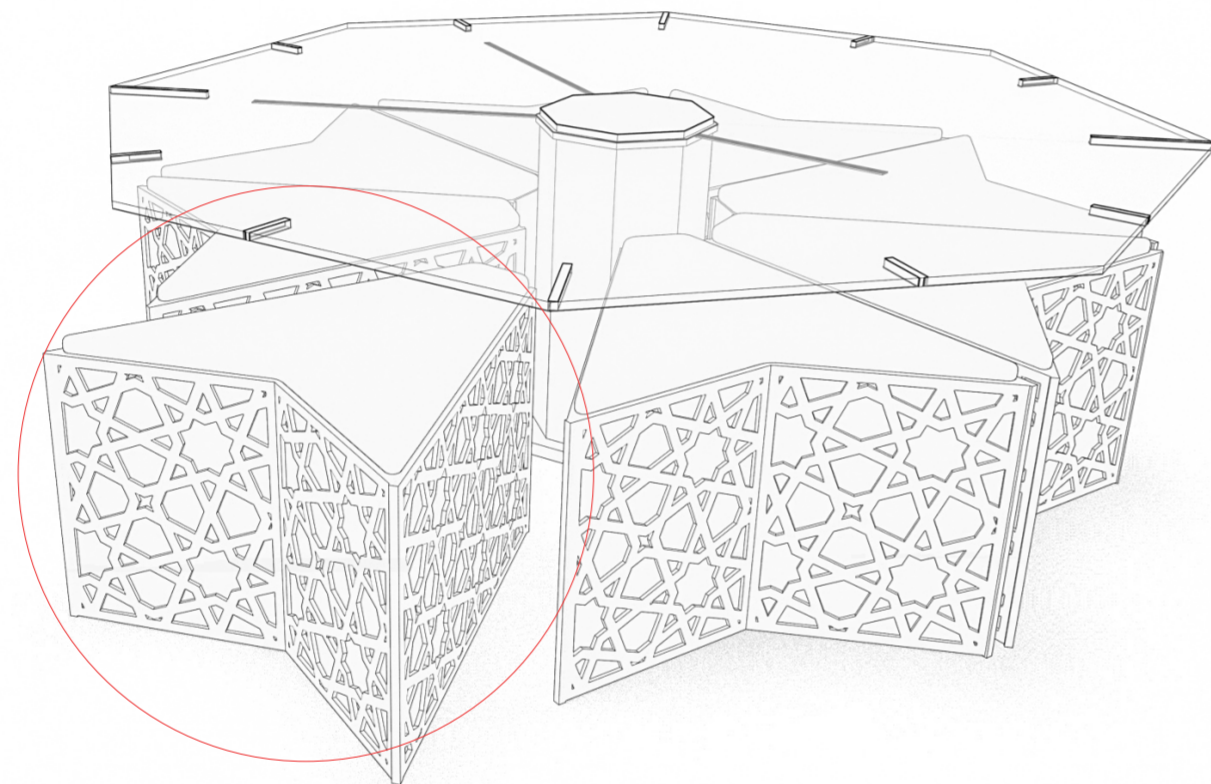

The Slimani Ring is composed by 8 modular pouf-type seats, with a triangular shape, designed to offer different shapes and combinations.

These seats can be used with the Clock Table, (an octagonal-shaped glass table, inspired by Ruba Al Hizb), or separately for various functions (supports objects, feet, etc.)



SKETCHES

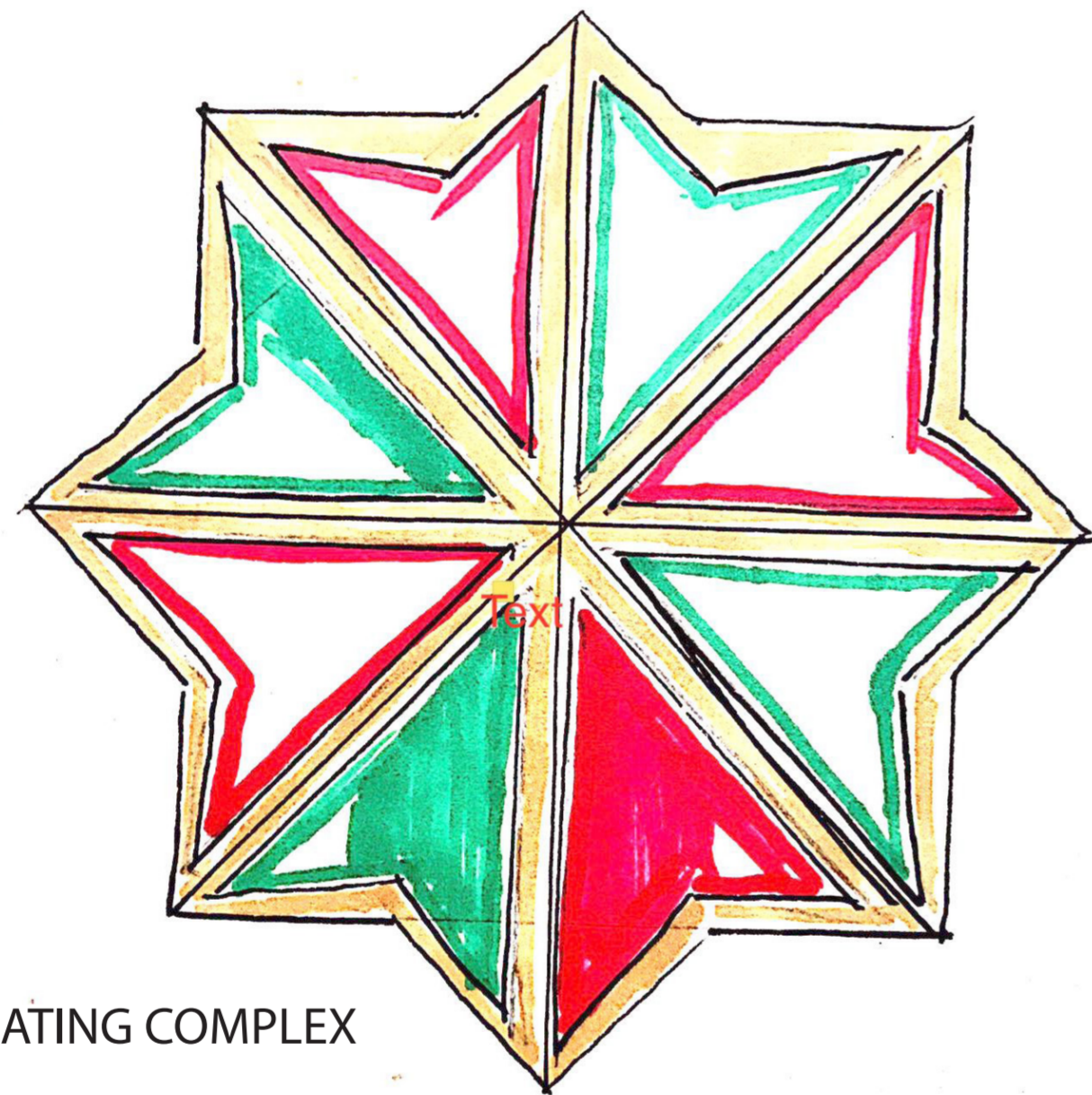

SEATING COMPLEX

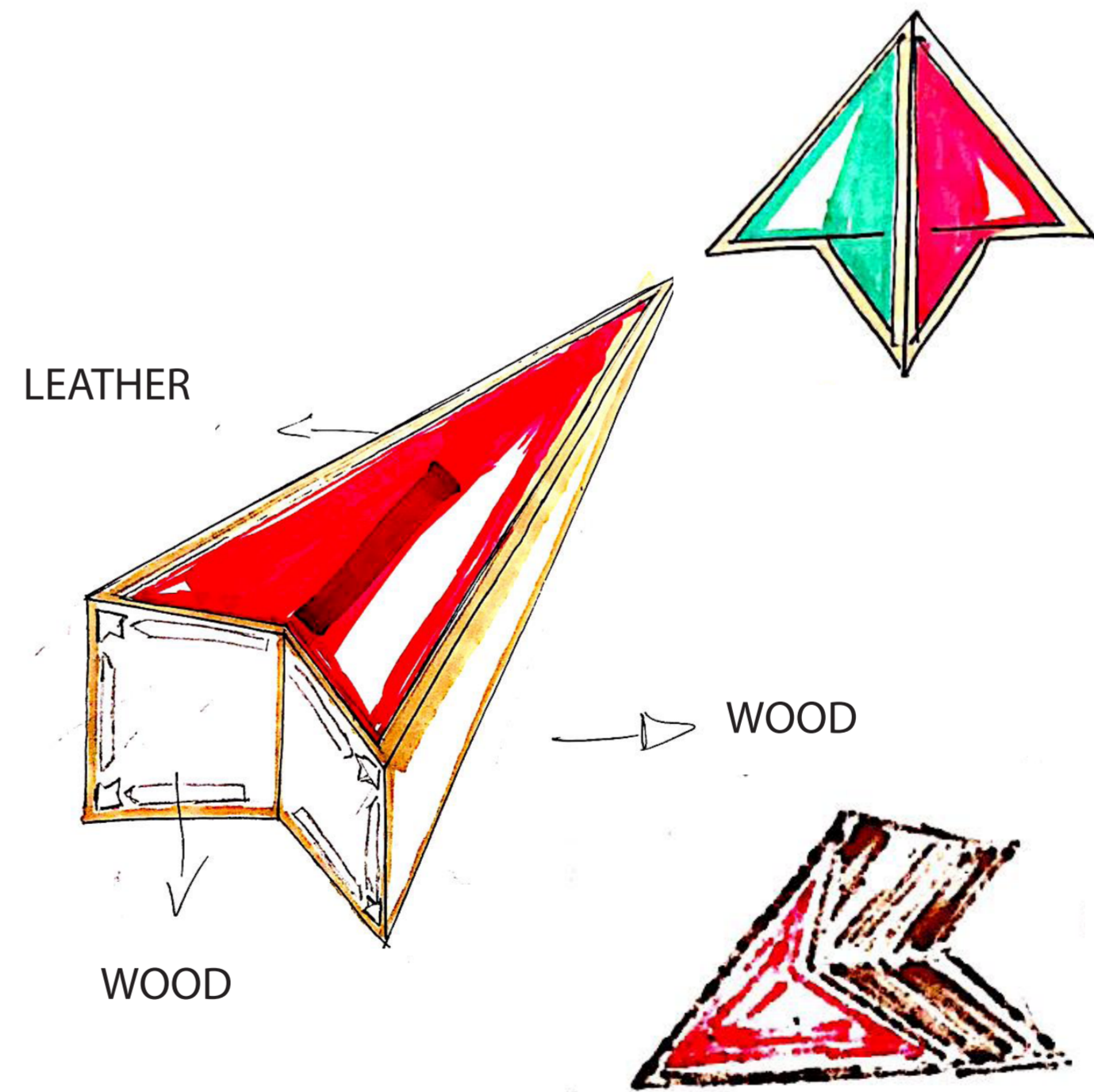

LEATHER

WOOD

WOOD

## PRODUCT'S TECHNICALS

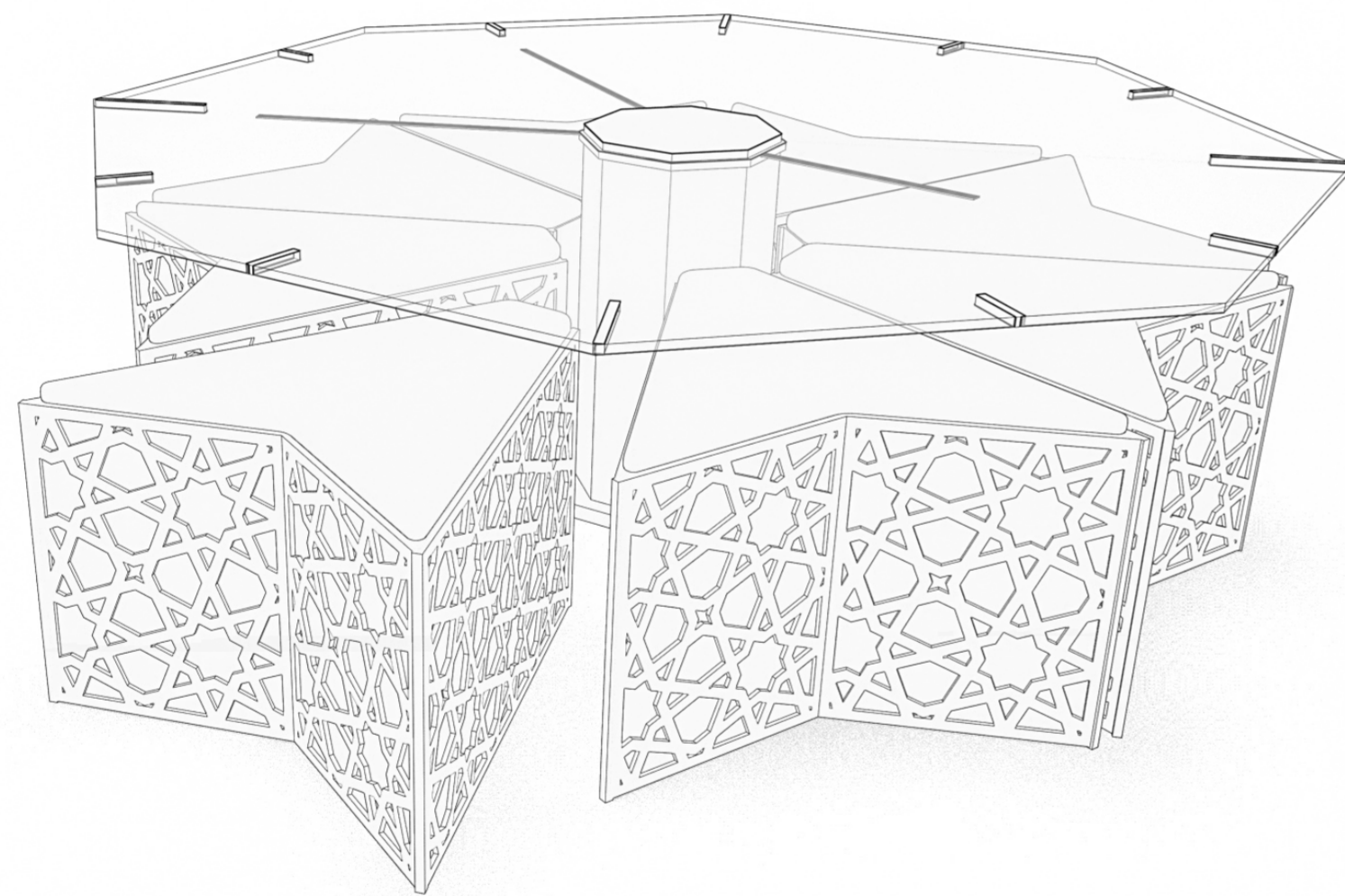

# 1. SEAT TECHNICALS

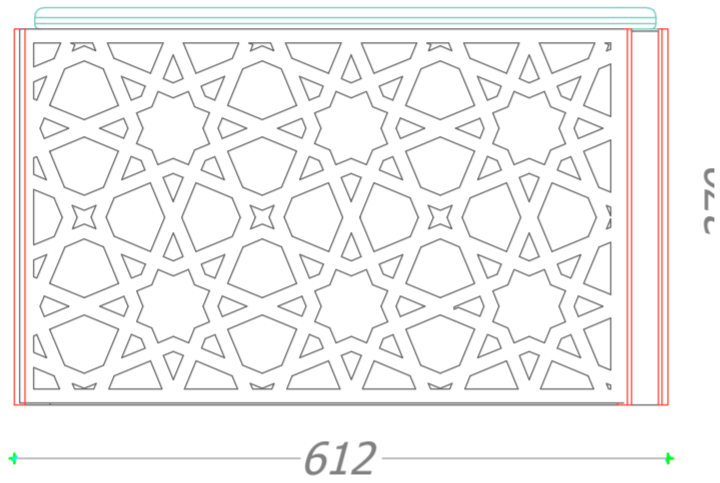

LATERAL VIEW - A -

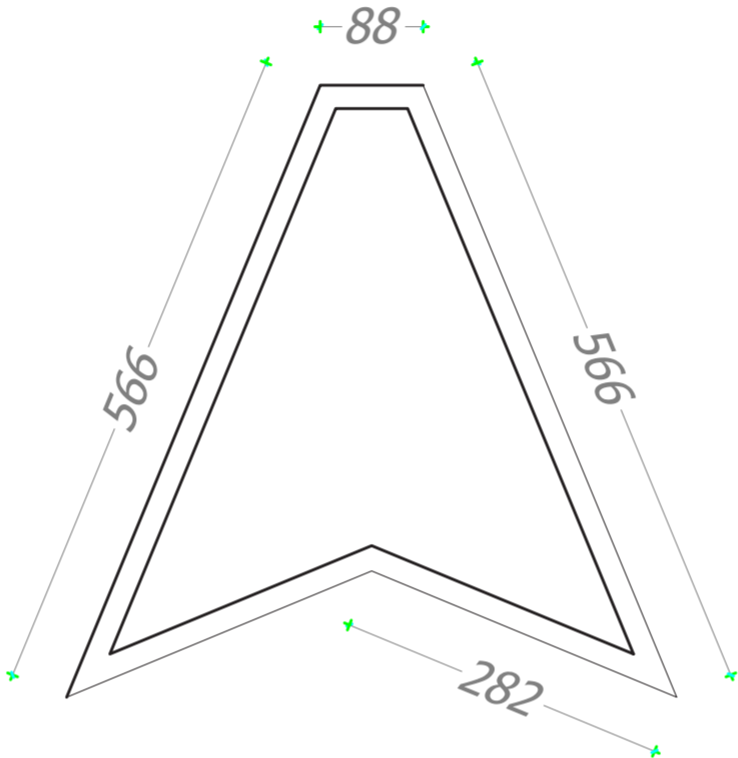

PLANT VIEW

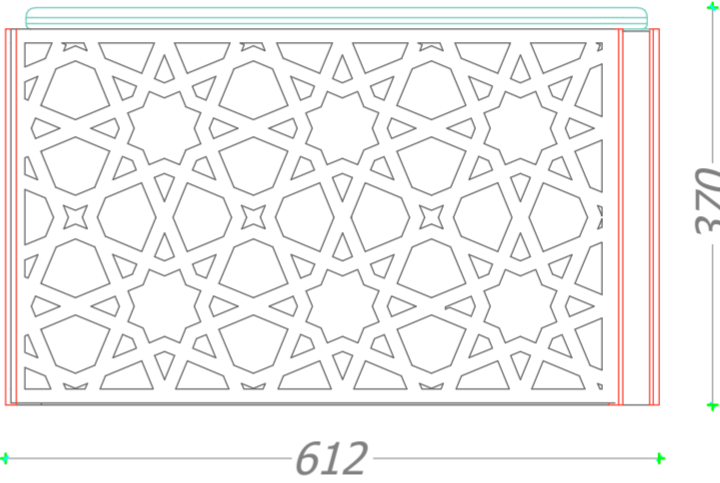

LATERAL VIEW-B -

MEASUREMENTS  
IN mm

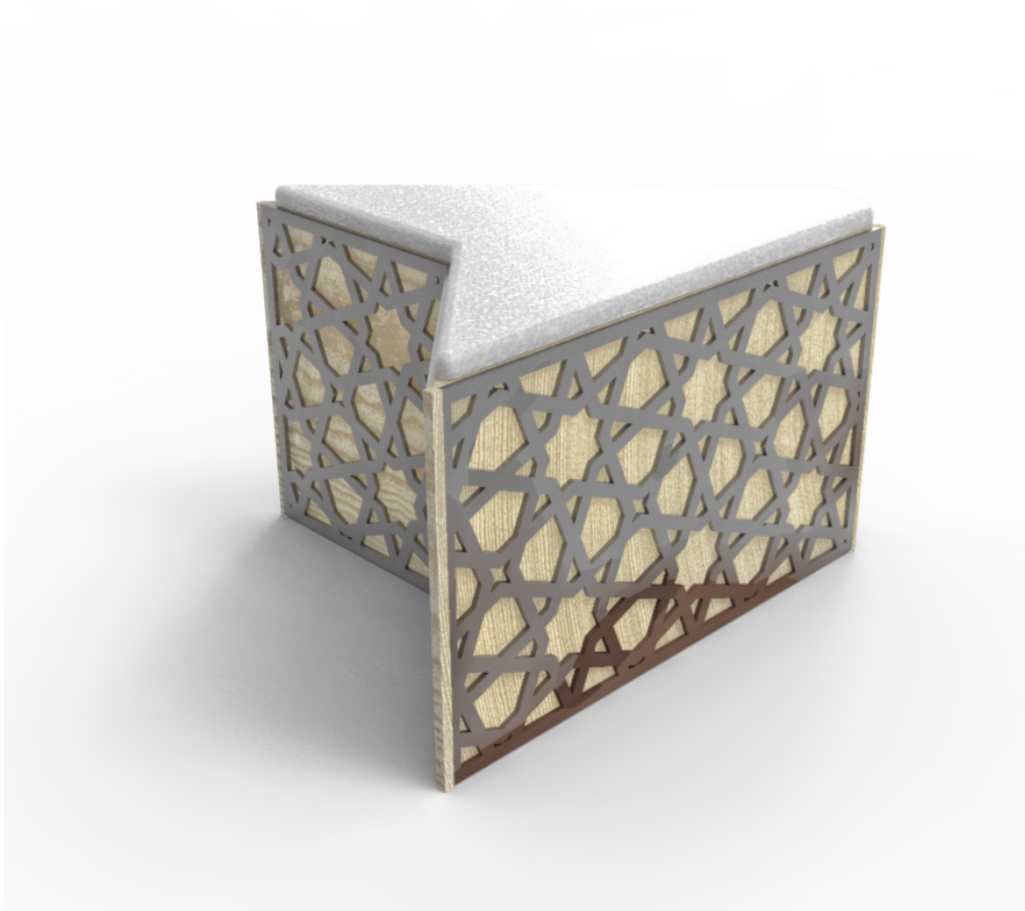

THREE-DIMENSIONAL VIEW

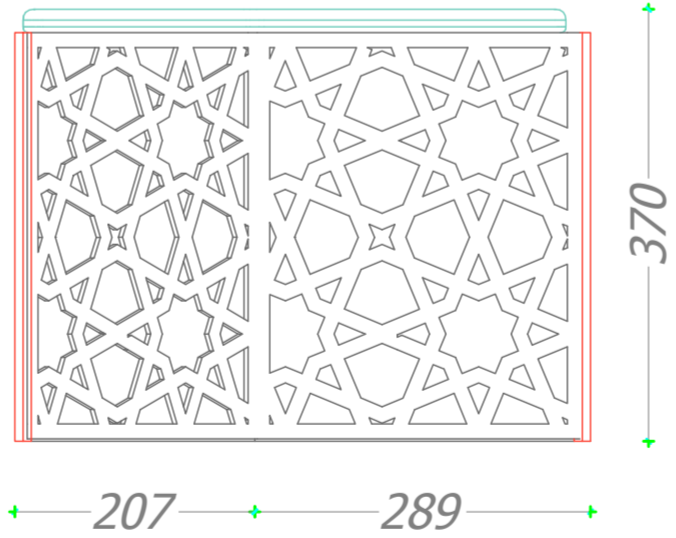

BACK VIEW

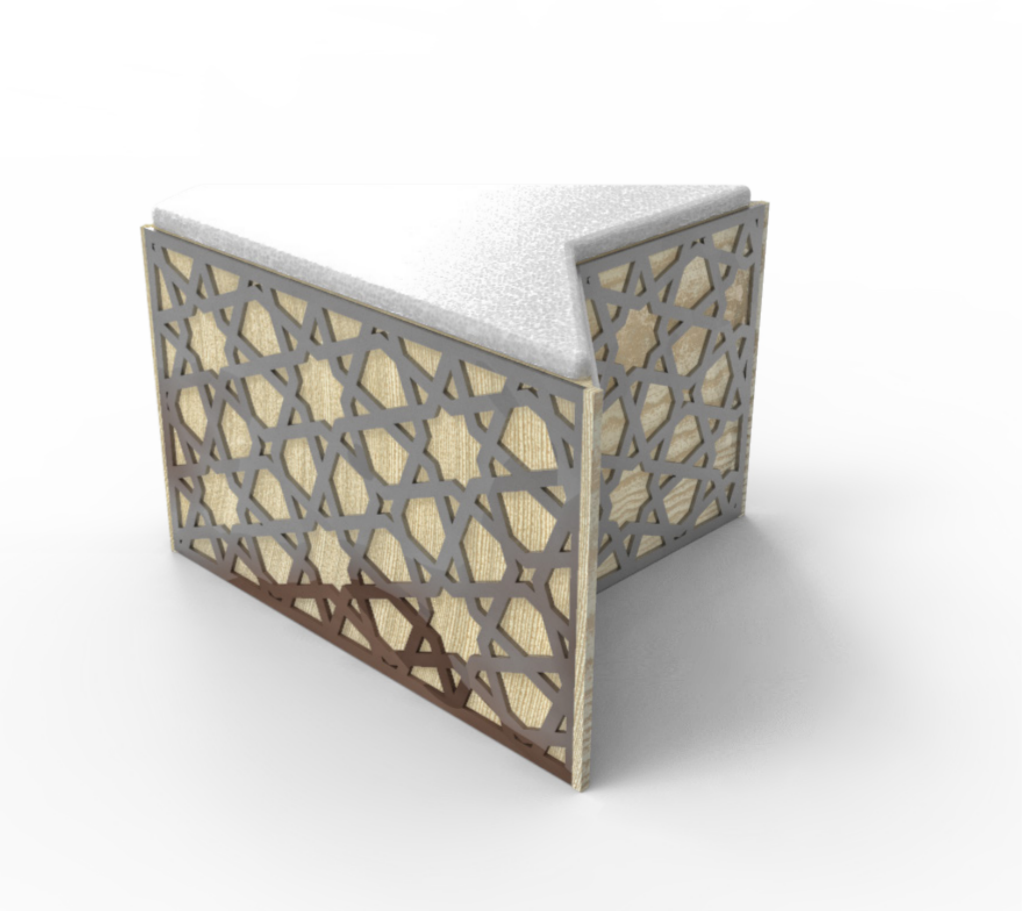

THREE-DIMENSIONAL VIEW

1a. SEATING COMPLEX

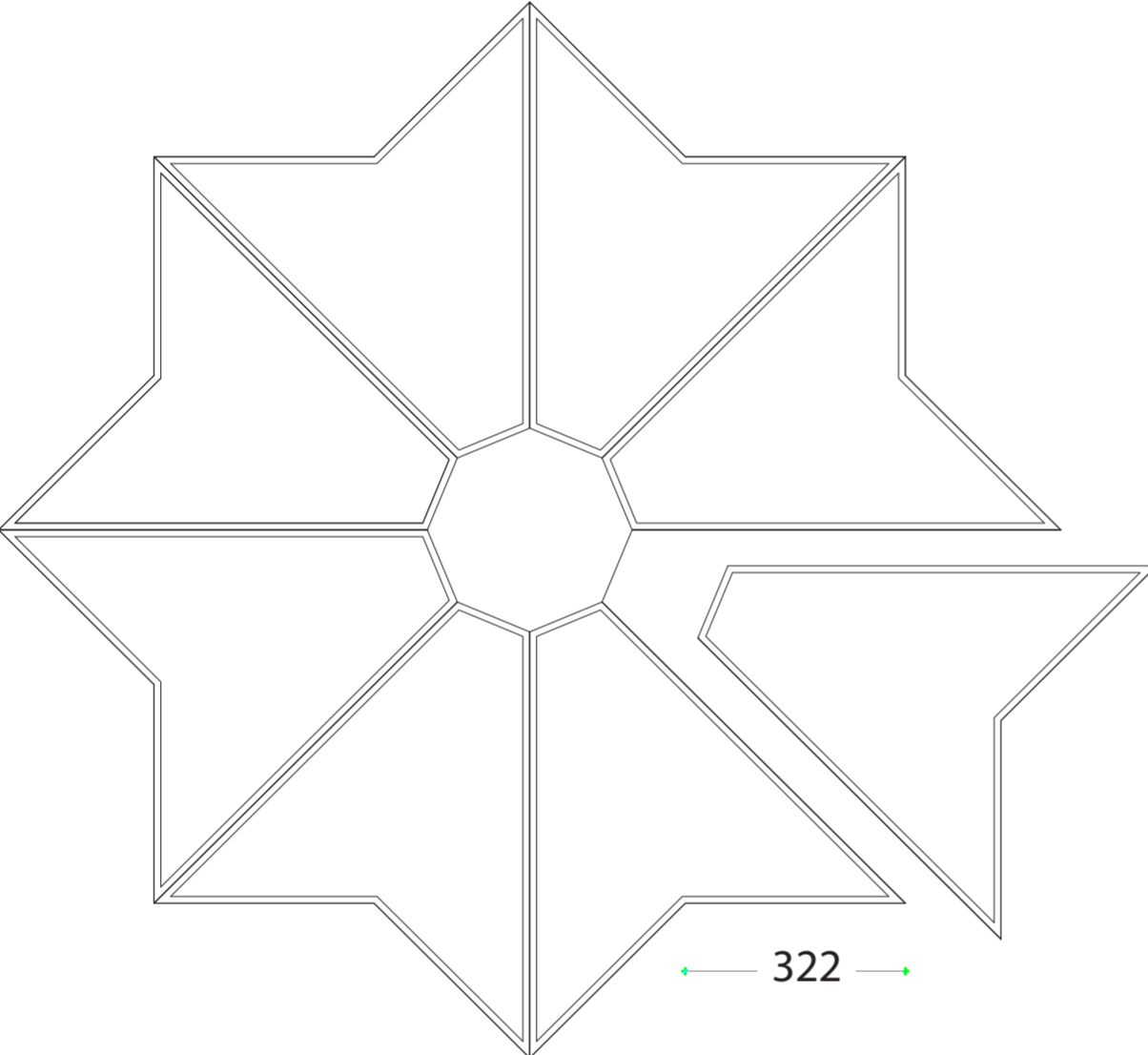

PLANT VIEW - MEASUREMENTS IN mm

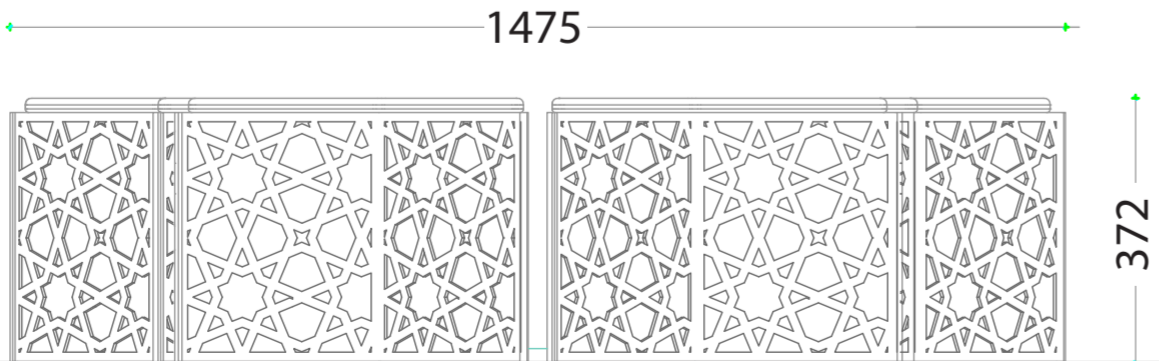

LATERAL VIEW- MEASUREMENTS IN mm

L.T.

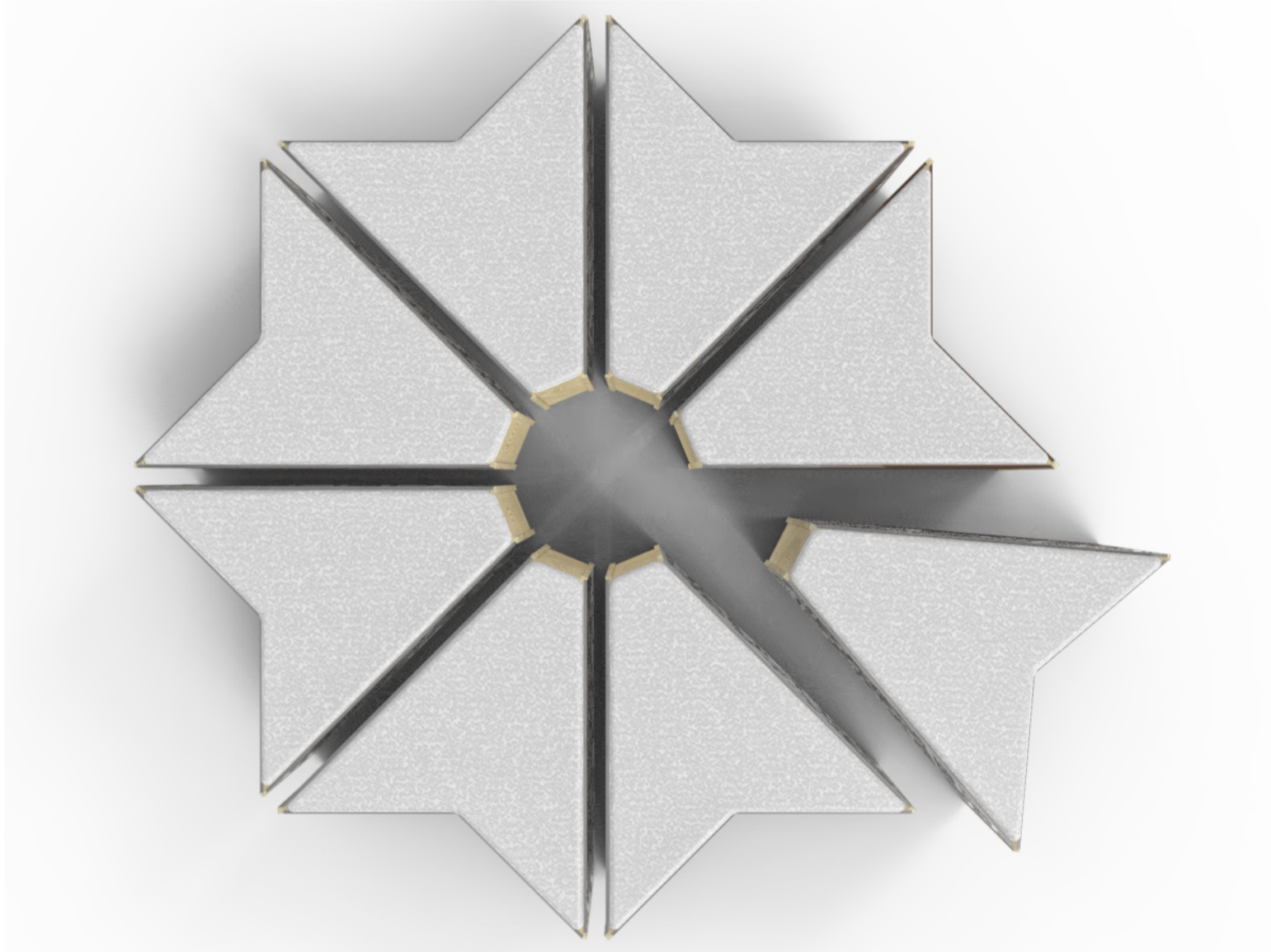

THREE-DIMENSIONAL VIEW

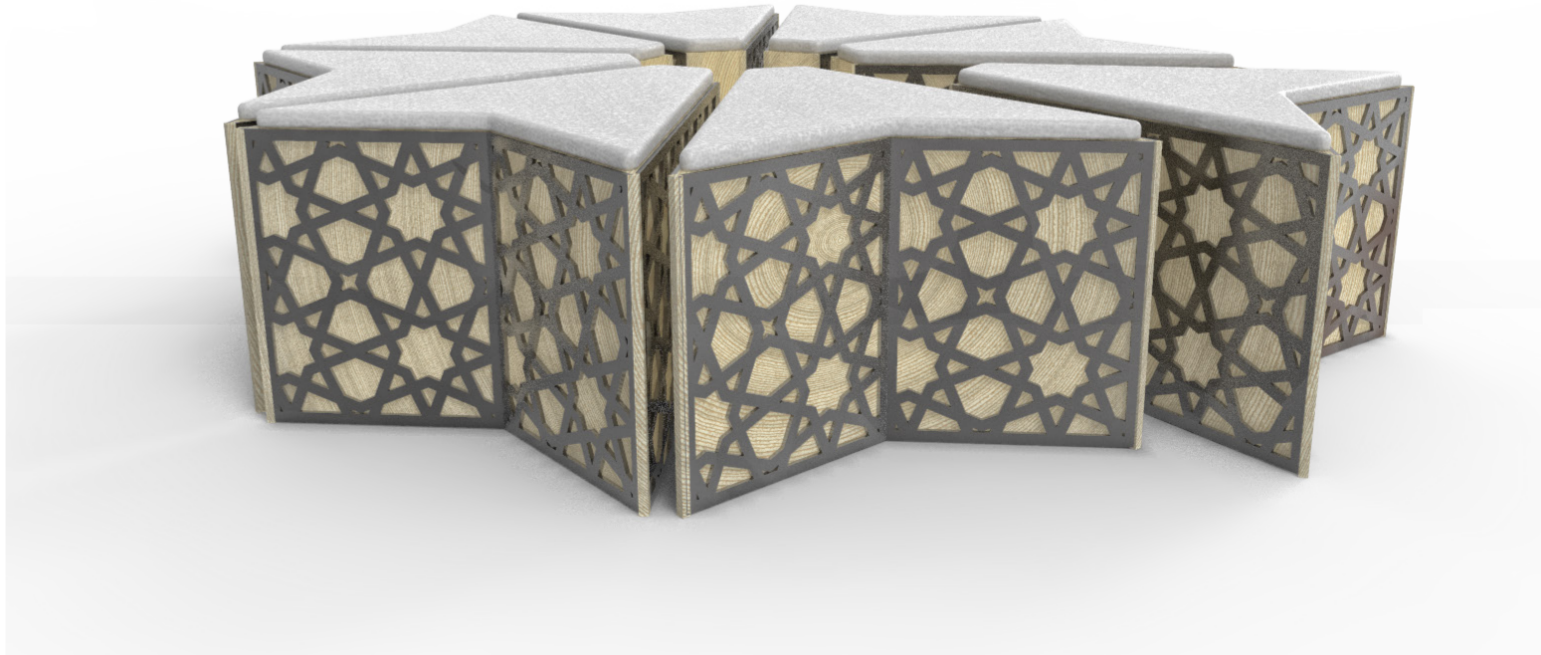

## 2. CLOCK TABLE

The second component of the Slimani Ring is the Clock Table, made of glass with an octagonal shape inspired by Ruba Al Hizb.

Having considered the use of this product both in homes and in public places such as shopping centers, airports and / or even as a table in a meeting room, we considered it useful and functional to integrate a clock into our product.

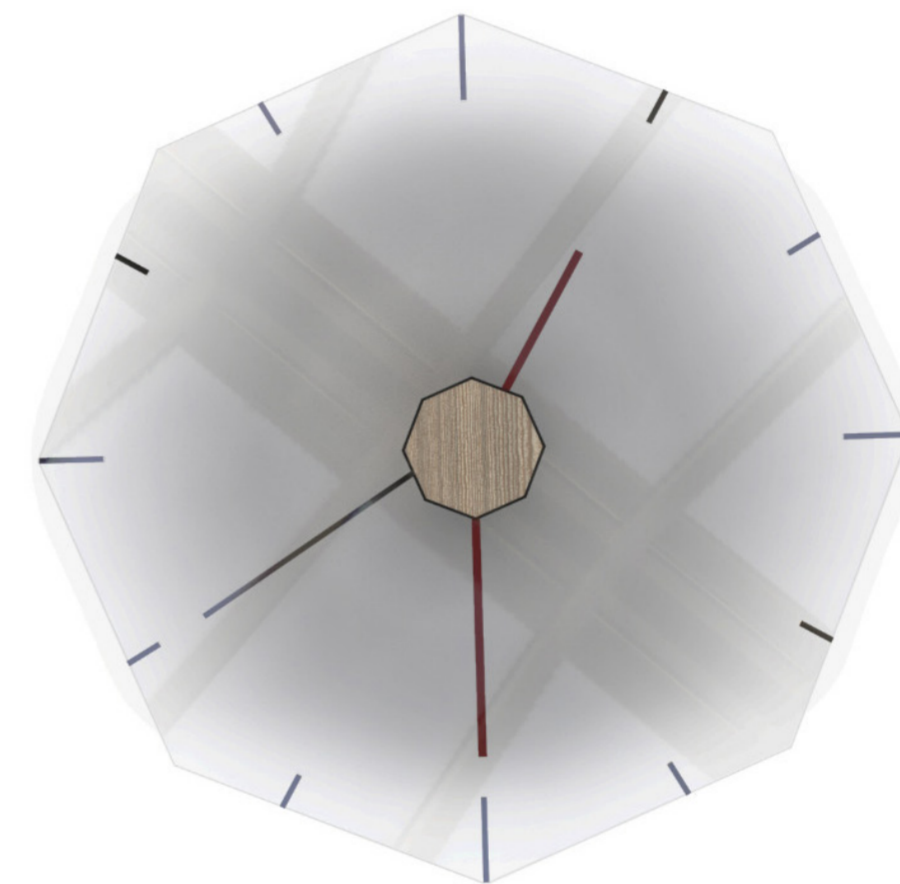
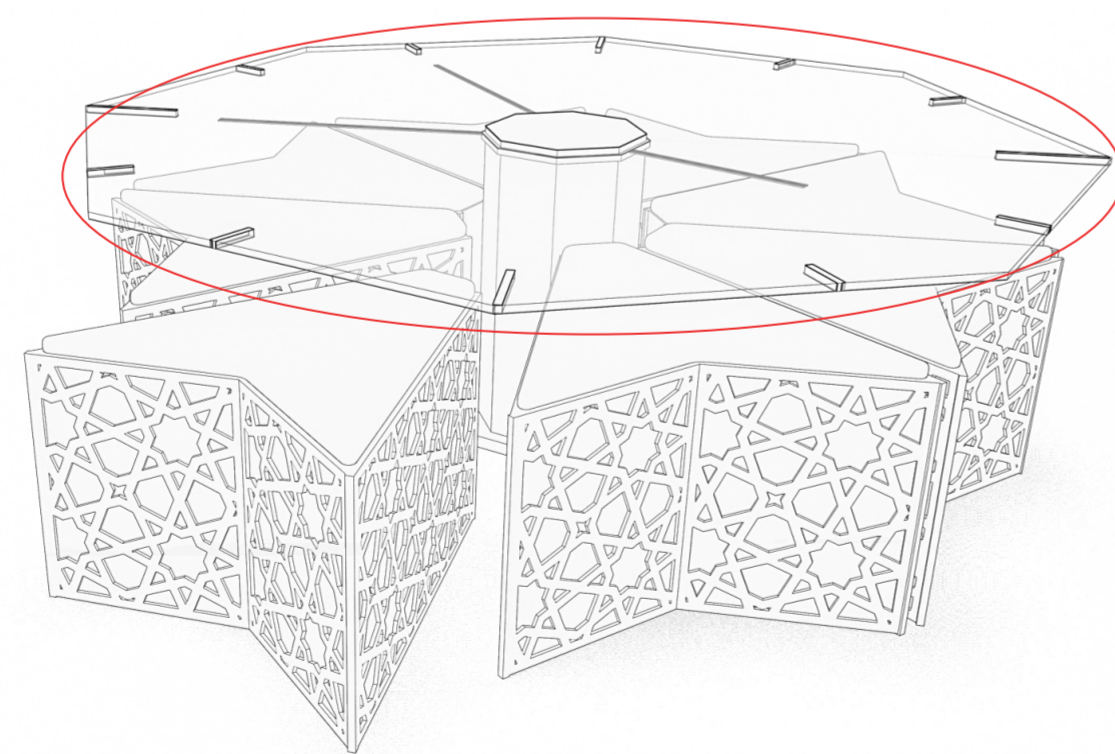

## 2a. CLOCK TABLE

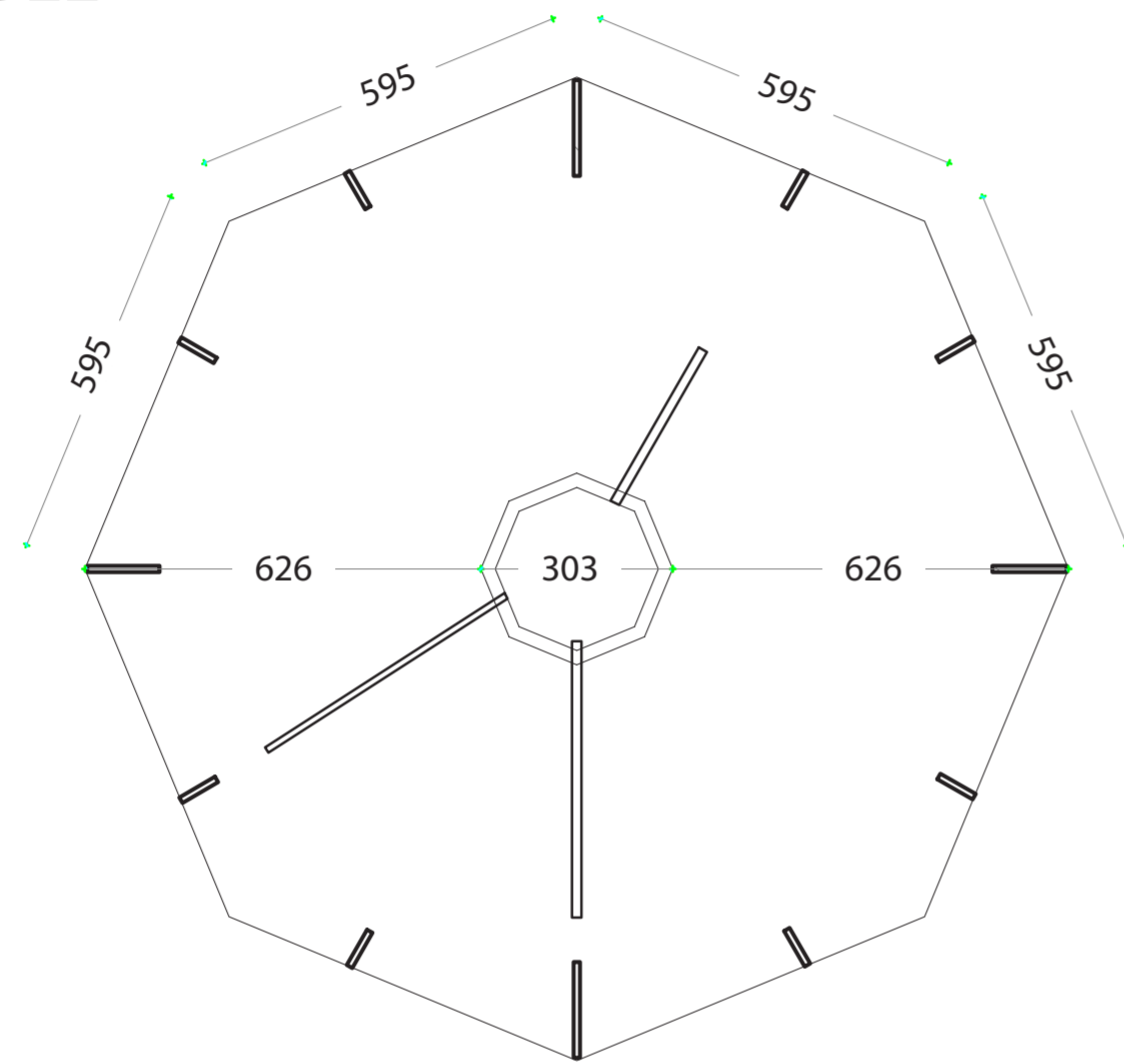

PLANT VIEW - MEASUREMENTS IN mm

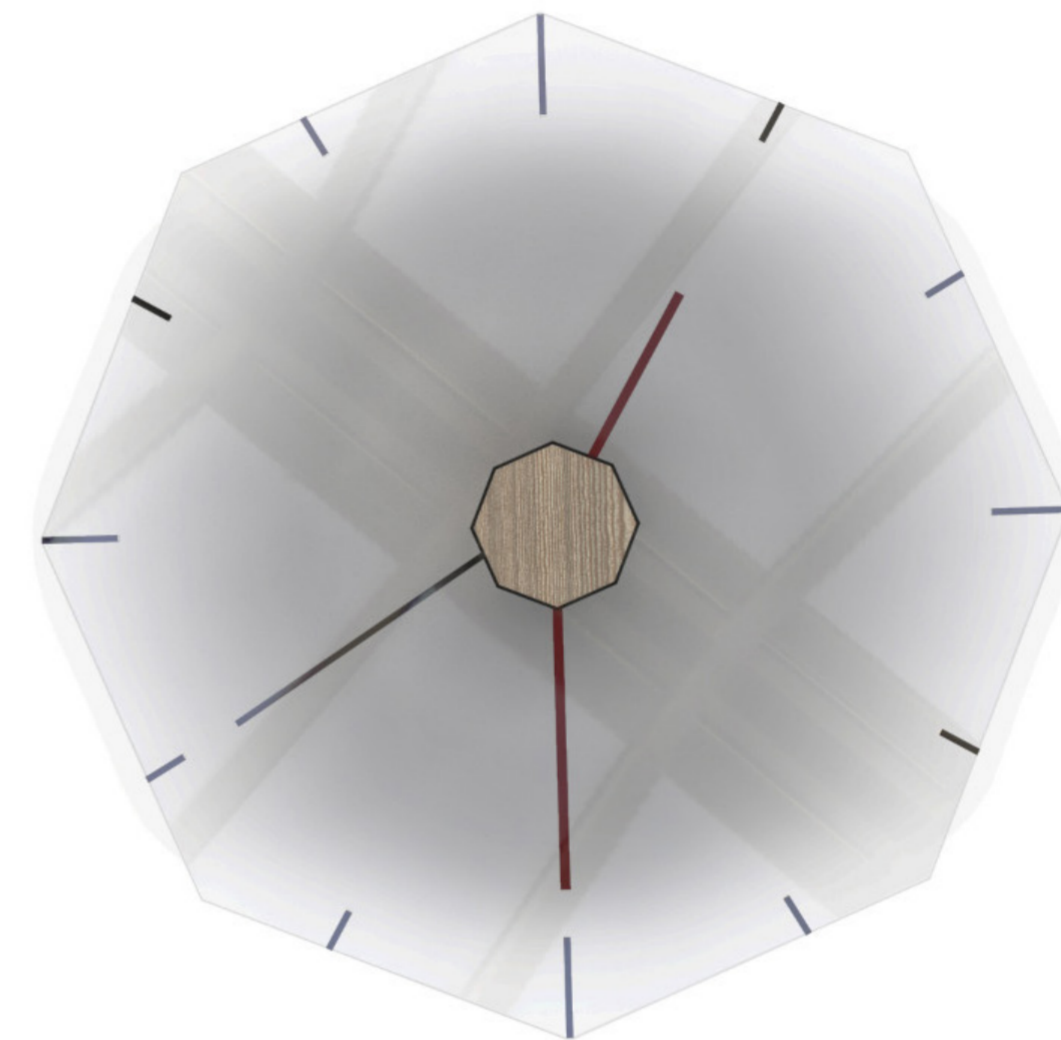

PLANT VIEW

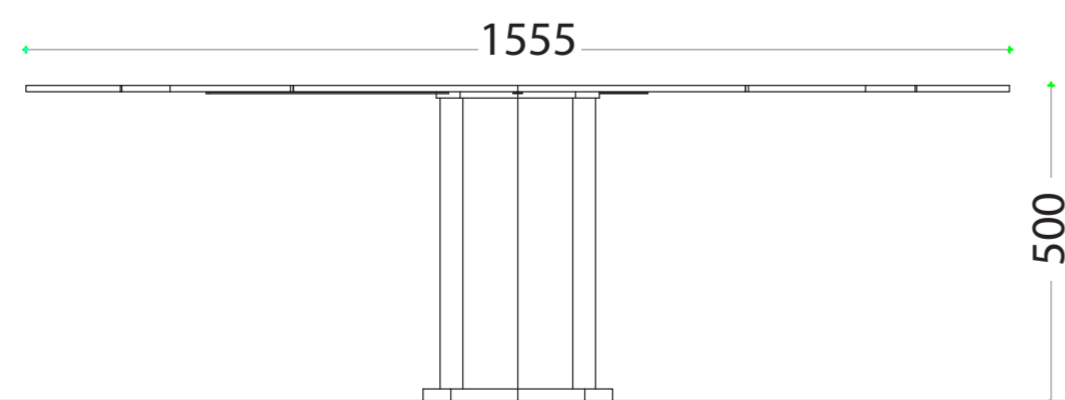

LATERAL VIEW- MEASUREMENTS IN mm

L.T.

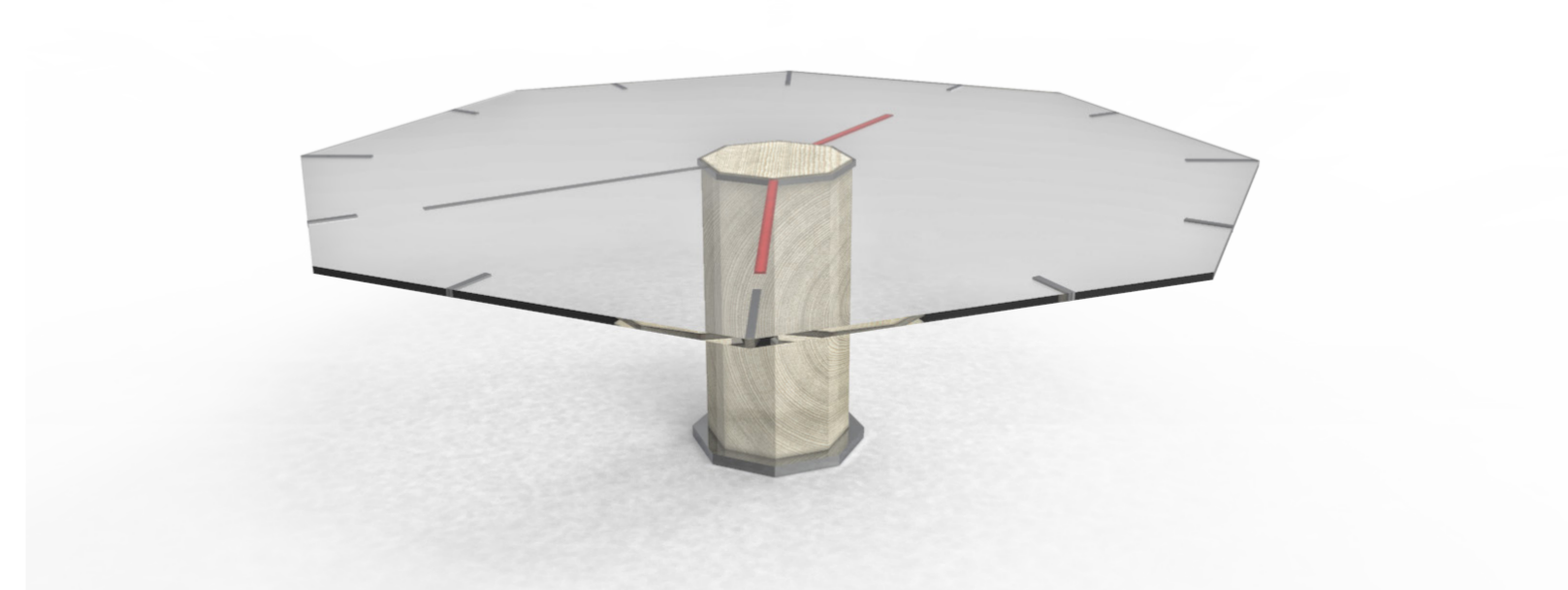

THREE-DIMENSIONAL VIEW

SLIMANI RING  
SEATS + TABLE

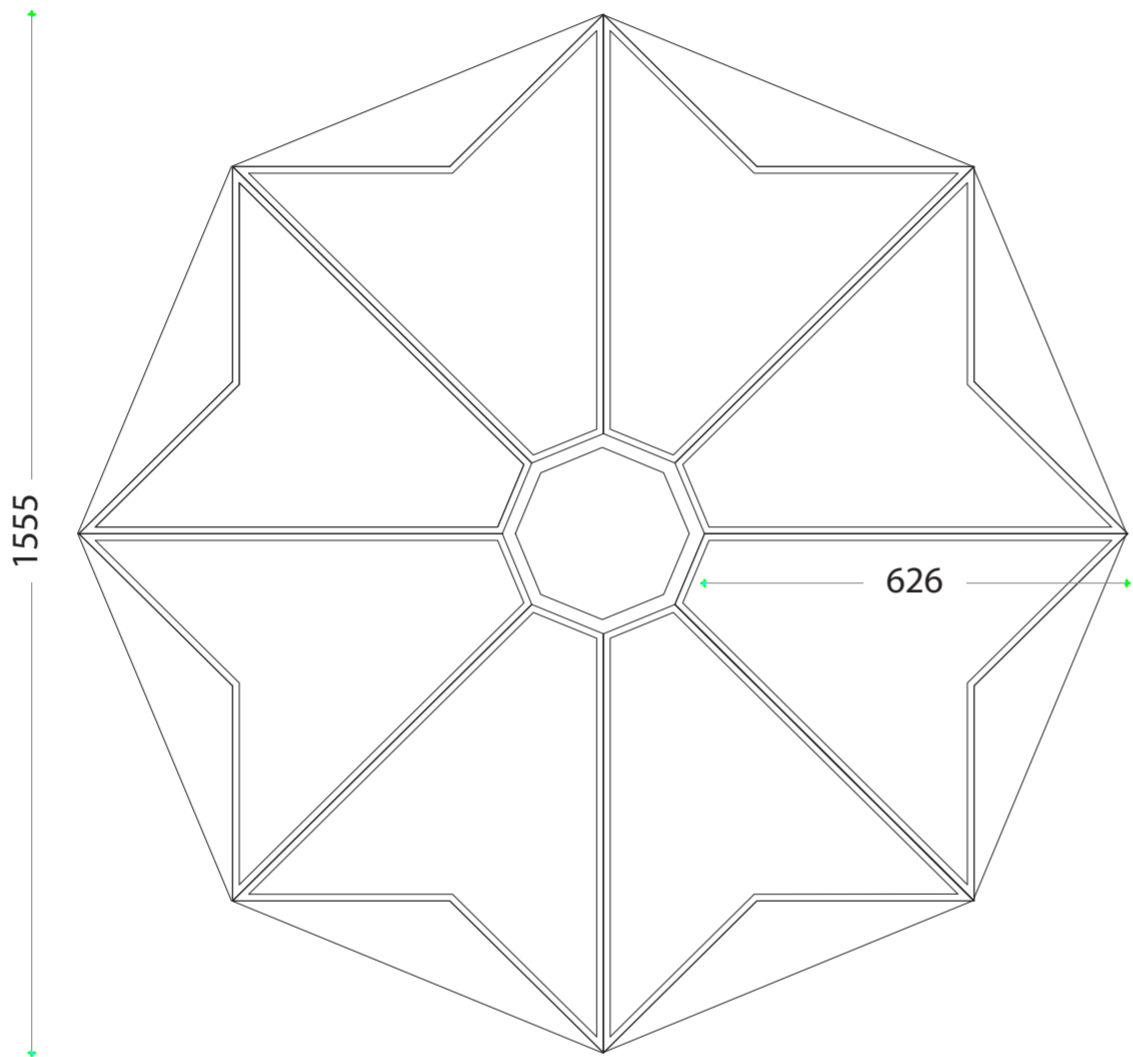

PLANT VIEW - MEASUREMENTS IN mm

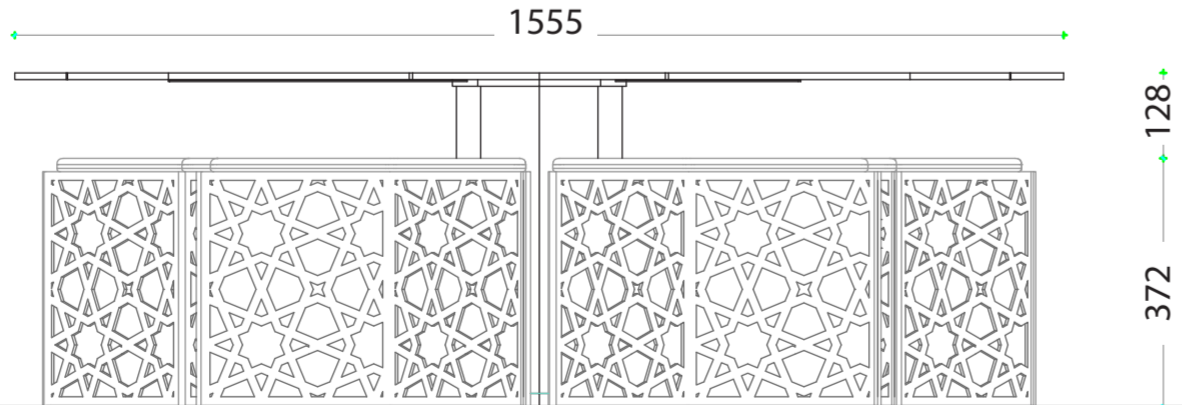

LATERAL VIEW - MEASUREMENTS IN mm

L.T.

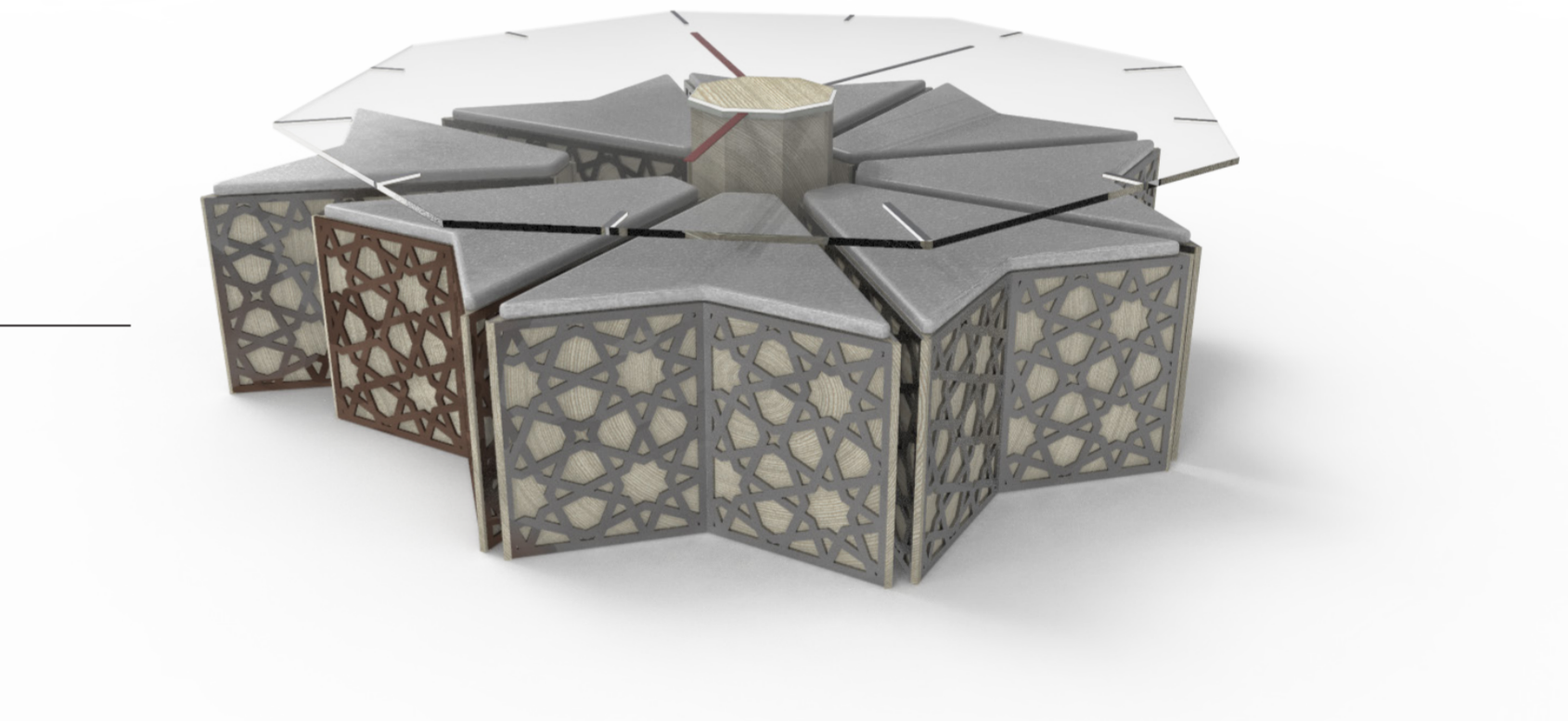

THREE-DIMENSIONAL VIEW

# MATERIALS

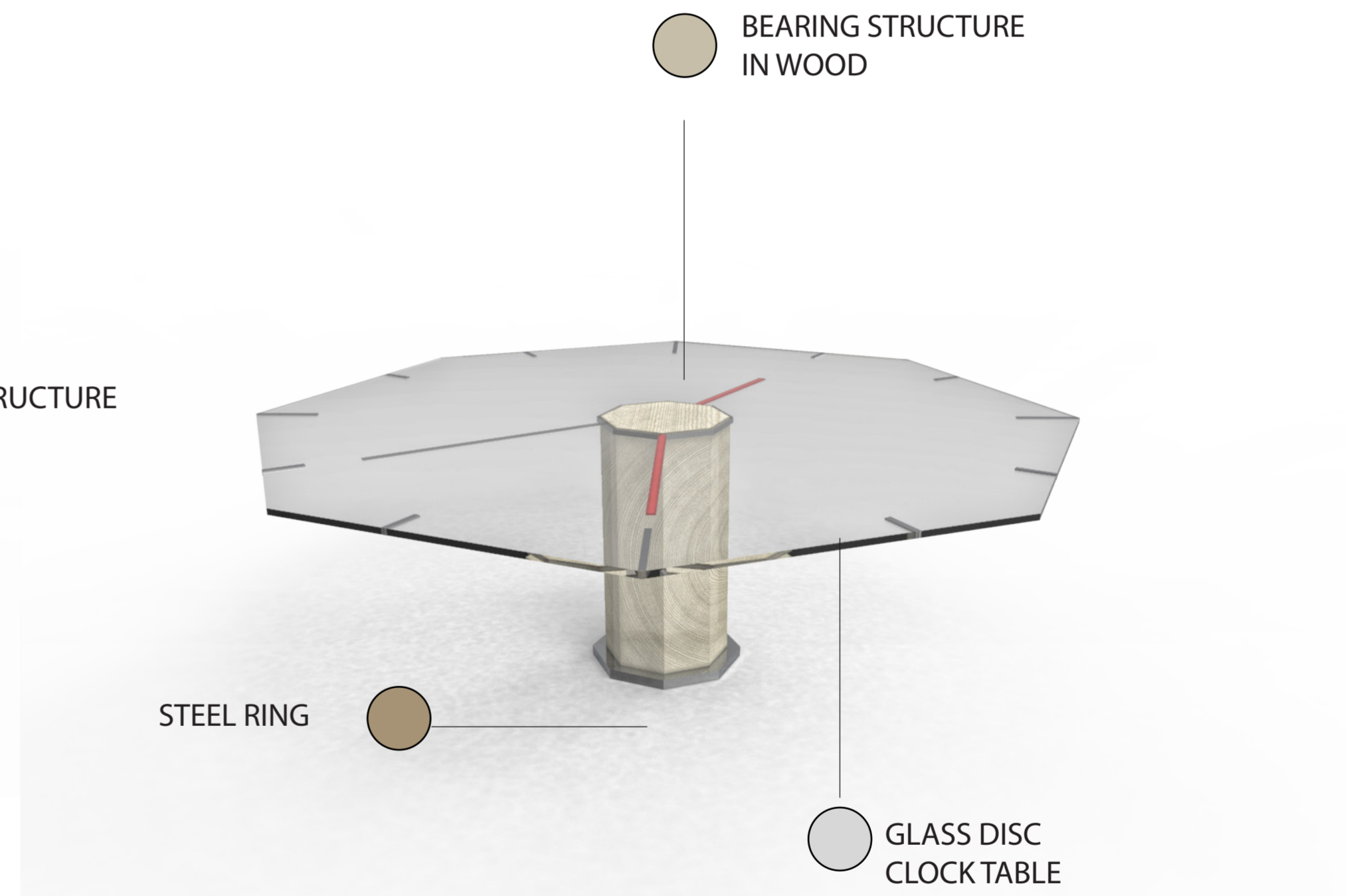
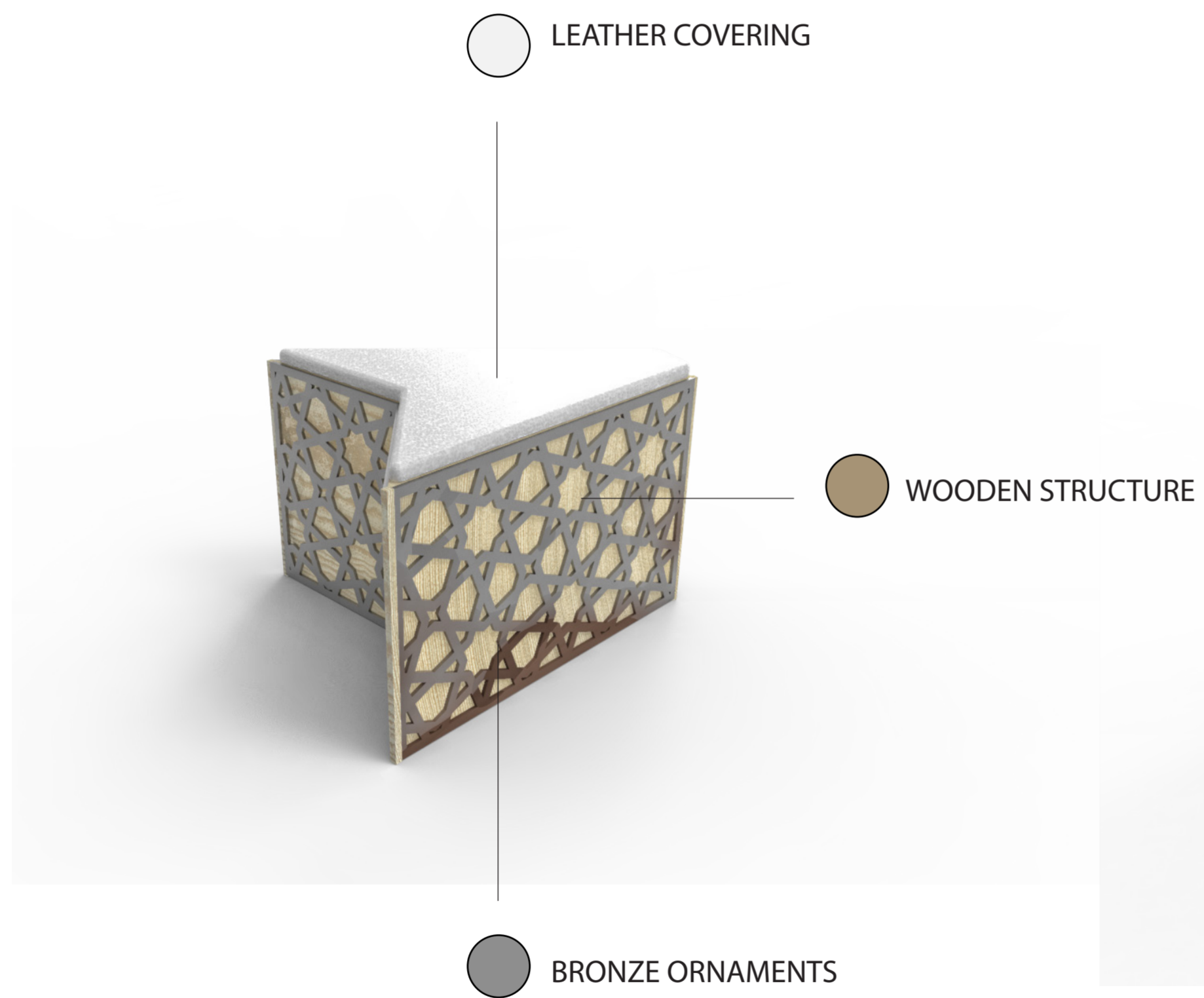



## ENVIRONMENT

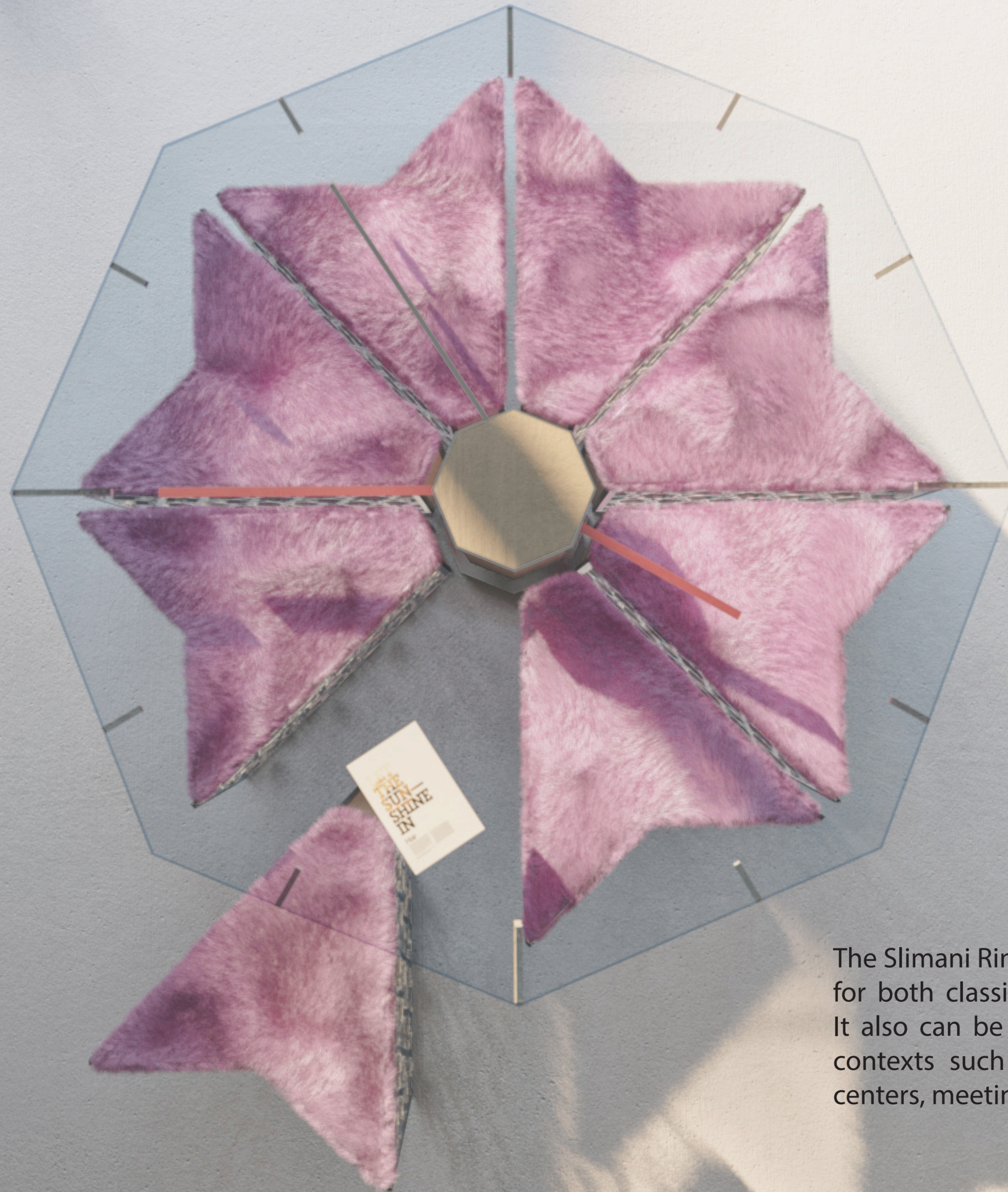

The Slimani Ring is a piece of furniture suitable for both classical and modern environments. It also can be easily integrated into different contexts such as homes, airports, shopping centers, meeting rooms, etc..







## CONCLUSION

---

**The Slimani Ring can be seen as a living room in itself, positioned in both classic and modern environments.  
evoking modernity in classic contexts and classicism in modern contexts.**

---

MADE BY:



**ISMAEL ALAOUI ALAMI**  
- Interior Designer -

email: [alamismael96@gmail.com](mailto:alamismael96@gmail.com)



**FATMA MOSTEF**  
- Interior Designer -  
- Building survayor -  
- Building Expert -

email: [fatma.mostef@gmail.com](mailto:fatma.mostef@gmail.com)



**MOHAMED M'OUYH**  
- Building Expert -

email: [mohammedmouyh@gmail.com](mailto:mohammedmouyh@gmail.com)